

Technical Data Sheet

Date: 03/11/2022

3x32A CEE Norm Angled Panel Mount App. Inlet

Ref. No: 3125-318-0900



Pack Unit

5



Weight

213 gr.



Technical Informations

Ampere	32A
Voltage	200 - 250 V. AC
Hertz	50 - 60 Hz
Protection Class	IP 67
Clock Postion	6h
Number Of Poles	3 (2P + E)
Contact Material	Brass (CuZn)
Housing Material	PA6
Connection Type	Screw
Operation Temp. (-25 / + 40 IEC 60309)	-25 / +80 (1 hour -100° C)

Dimensions

a	85	e	126
b	85	f	102
c	70	Øh	6,3
d	70	Øl	50
Cable Diameter (Min.)	2,5 mm ²		
Cable Diameter (Max.)	6 mm ²		

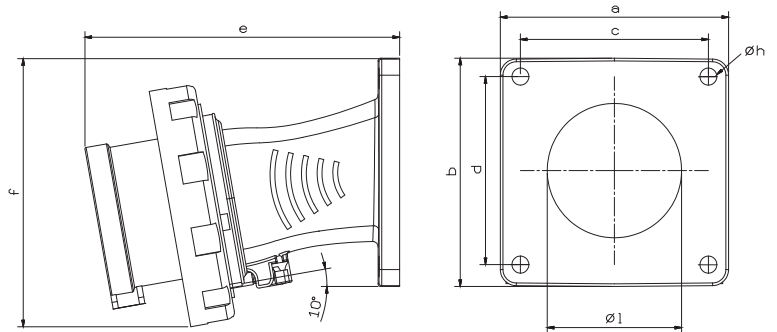

Different Earth Contact Positions (Clock Positions)

 >50V 300-500 Hz 2h	 100-130V 50-60 Hz 4h	 200-250V 50-60 Hz 6h	 480-500V 50-60 Hz 7h	 380-415V 50-60 Hz 9h
3125-318-1100-2h	3125-318-0700-4h	3125-318-0900	3125-318-0300-7h	3125-318-1600-9h



Tel: +90 232 880 90 01
Fax: +90 232 880 90 02



info@tpelectric.com.tr



Kemalpaşa O.S.B. 600 Sk. No:364
35730 Kemalpaşa - İZMİR / TÜRKİYE